

Handcrafted in
New Zealand
since 1887



 **WOODSMAN**



Feeling real.



Each wood burner is ergonomically designed to be easy to light and clean, offering an elegant home heating solution that is not only high performance, but also low impact, being the epitome of sustainability with a carbon neutral footprint. Yes, really.



Real feeling.

Woodsman fires make you feel at home. Creating the comforting glow of an energy efficient wood burner that runs with a pleasant, even temperature — emanating from an expertly crafted design suitable for any Kiwi home.



Lower emissions. Feel better.

New Zealand has some of the strictest clean air standards in the world. Every Woodsman fire outperforms the testing standards for emissions meaning there is a Woodsman that fits the clean air profile for New Zealand homes in any region.

Sustainable and carbon neutral.

Yes, neutral.



SUSTAINABLE

Our fires are crafted from sturdy materials that are made to withstand the test of time. The majority of our components are recyclable. We aim to make each Woodsman the model of sustainability. We put quality first, so they are built to last.

CARBON NEUTRAL

During its lifetime, a tree absorbs a huge amount of carbon dioxide. When you burn wood, that same CO₂ is released back to the atmosphere ready to be reabsorbed by replanted trees. If you burn wood from a reliable renewable source, then using a Woodsman adds no CO₂ to the earth's carbon load.

Hand crafted in
New Zealand since

1887



W.H. Harris



1920 - Staff photograph

Family history. A real legacy.

Woodsman wood burners are designed and handcrafted in New Zealand by Harris Home Fires. We've been warming Kiwi homes since 1887. A real family business that spans generations, we remain committed to handcrafting your Woodsman fire to the most exacting standards, using generations of collected experience to deliver outstanding craftsmanship.

New Zealand made.

Feel the quality.

High impact ceramic glass, mild steel, hand crafted welding – words you never see on a heat pump brochure. A Woodsman is an addition to a home that brings value not just today, but also for years and years to come. Your new Woodsman is built to last both in the way it looks and the way it runs. When you see one up close you can literally feel the quality.





Heating Space Calculator

Calculate with real precision which Woodsman feels right for your home.

This simple four step process will help you identify the Woodsman fires that are ideal for your home using Harris Home Fires' proven calculation system.

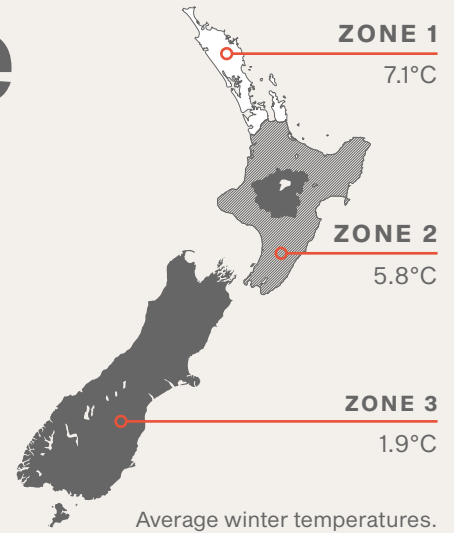

1 SELECT YOUR ZONE
In which zone do you live? The country is divided into three areas according to the average daily minimum outdoor air temperature.

2 SELECT THE AGE OF YOUR HOME
This will determine insulation levels. If your home insulation has been upgraded or double glazing has been retrofitted, choose the next category up.

3 SELECT THE M² SIZE OF YOUR HEATING SPACE
Be realistic when choosing this size. Match the area to the space you are trying to heat, and bear in mind these calculations are based on a ceiling height of 2.4m.

ZONE 1



Age of Home	10 m ²	20 m ²	30 m ²	40 m ²	50 m ²	60 m ²	70 m ²	80 m ²
Pre 1978	2.2 kW	3.5 kW	4.6 kW	5.6 kW	6.5 kW	7.5 kW	8.4 kW	9.3 kW
1978–1996	1.7 kW	2.5 kW	3.3 kW	4 kW	4.6 kW	5.2 kW	5.8 kW	6.3 kW
1996–2004	1.4 kW	2.1 kW	2.7 kW	3.3 kW	3.8 kW	4.3 kW	4.8 kW	5.2 kW
2004–2009	1.6 kW	2.4 kW	3.1 kW	3.6 kW	4.2 kW	4.7 kW	5.2 kW	5.7 kW
Post 2009	1 kW	1.6 kW	2 kW	2.5 kW	2.9 kW	3.3 kW	3.6 kW	4 kW

ZONE 2



Age of Home	10 m ²	20 m ²	30 m ²	40 m ²	50 m ²	60 m ²	70 m ²	80 m ²
Pre 1978	2.4 kW	3.7 kW	4.9 kW	6 kW	7.1 kW	8.1 kW	9 kW	10 kW
1978–1996	1.8 kW	2.7 kW	3.6 kW	4.3 kW	5 kW	5.6 kW	6.2 kW	6.8 kW
1996–2004	1.5 kW	2.3 kW	3 kW	3.6 kW	4.1 kW	4.6 kW	5.1 kW	5.6 kW
2004–2009	1.7 kW	2.6 kW	3.3 kW	3.9 kW	4.5 kW	5.1 kW	5.6 kW	6.2 kW
Post 2009	1.1 kW	1.7 kW	2.2 kW	2.7 kW	3.1 kW	3.5 kW	3.9 kW	4.3 kW

ZONE 3



Age of Home	10 m ²	20 m ²	30 m ²	40 m ²	50 m ²	60 m ²	70 m ²	80 m ²
Pre 1978	2.9 kW	4.5 kW	6 kW	7.3 kW	8.6 kW	9.8 kW	11 kW	12.2 kW
1978–1996	2.2 kW	3.4 kW	4.3 kW	5.2 kW	6.1 kW	6.9 kW	7.6 kW	8.4 kW
1996–2004	1.8 kW	2.7 kW	3.4 kW	4.1 kW	4.7 kW	5.4 kW	5.9 kW	6.5 kW
2004–2009	1.4 kW	2.1 kW	2.7 kW	3.3 kW	3.8 kW	4.4 kW	4.8 kW	5.3 kW
Post 2009	1.3 kW	2 kW	2.6 kW	3.2 kW	3.7 kW	4.2 kW	4.7 kW	5.1 kW

How does this calculator work?

The Heating Space Calculator is based on maintaining a comfortable room temperature of 23°C with a 2.4m ceiling height. It does this

by estimating the 'Heat Loss Value (kW)' – taking into account your region, age of home and room dimensions – what we like to call 'the sweet spot.'

WHY IS THIS CALCULATION SYSTEM PREFERRED?

REAL DATA VS PEAK MOMENT.

Wood fires do not produce a constant heat output. After loading wood, the output will increase dramatically and then cool down significantly before you reload again.

This calculation system shows an average output taking into consideration the peaks and troughs and gives a genuine figure as to how much heat you will get out of the fire over a typical burn cycle.

While some brands represent their outputs at 'Peak', which is the very top of the heating curve, we prefer to show an accurate representation of a fire's true performance over time.

A calculator based on average output (like the one below) gives you a real performance value and lets you feel confident about correctly heating your chosen space.



90m ²	100m ²	110m ²	120m ²	130m ²	140m ²	150m ²	160m ²	170m ²	180m ²	190m ²	200m ²
10.1 kW	11.1 kW	11.8 kW	12.7 kW	13.5 kW	14.3 kW	15.1 kW	15.9 kW	16.7 kW	17.4 kW	18.2 kW	19 kW
6.9 kW	7.4 kW	7.9 kW	8.5 kW	9 kW	9.5 kW	10 kW	10.4 kW	10.9 kW	11.4 kW	11.9 kW	12.3 kW
5.7 kW	6.1 kW	6.5 kW	6.9 kW	7.3 kW	7.7 kW	8.1 kW	8.5 kW	8.9 kW	9.3 kW	9.6 kW	10 kW
6.2 kW	6.6 kW	7.1 kW	7.5 kW	7.9 kW	8.3 kW	8.7 kW	9.2 kW	9.6 kW	9.9 kW	10.3 kW	10.7 kW
4.3 kW	4.7 kW	5 kW	5.3 kW	5.6 kW	6 kW	6.3 kW	6.6 kW	6.9 kW	7.2 kW	7.5 kW	7.8 kW

90m ²	100m ²	110m ²	120m ²	130m ²	140m ²	150m ²	160m ²	170m ²	180m ²	190m ²	200m ²
10.9 kW	11.8 kW	12.8 kW	13.6 kW	14.5 kW	15.4 kW	16.3 kW	17.1 kW	18 kW	18.8 kW	19.7 kW	20.5 kW
7.4 kW	8 kW	8.6 kW	9.1 kW	9.7 kW	10.2 kW	10.7 kW	11.3 kW	11.8 kW	12.3 kW	12.8 kW	13.3 kW
6.1 kW	6.6 kW	7 kW	7.5 kW	7.9 kW	8.3 kW	8.7 kW	9.2 kW	9.6 kW	10 kW	10.4 kW	10.8 kW
6.7 kW	7.1 kW	7.6 kW	8.1 kW	8.5 kW	9 kW	9.4 kW	9.9 kW	10.3 kW	10.7 kW	11.2 kW	11.6 kW
4.7 kW	5 kW	5.4 kW	5.7 kW	6.1 kW	6.4 kW	6.8 kW	7.1 kW	7.4 kW	7.8 kW	8.1 kW	8.4 kW

90m ²	100m ²	110m ²	120m ²	130m ²	140m ²	150m ²	160m ²	170m ²	180m ²	190m ²	200m ²
13.3 kW	14.5 kW	15.6 kW	16.6 kW	17.7 kW	18.8 kW	19.9 kW	20.9 kW	21.9 kW	23 kW	24 kW	25 kW
9.1 kW	9.8 kW	10.5 kW	11.2 kW	11.8 kW	12.5 kW	13.1 kW	13.8 kW	14.4 kW	15 kW	15.7 kW	16.3 kW
7 kW	7.6 kW	8.1 kW	8.6 kW	9.1 kW	9.6 kW	10.1 kW	10.5 kW	11 kW	11.5 kW	11.9 kW	12.4 kW
5.8 kW	6.3 kW	6.7 kW	7.1 kW	7.6 kW	8 kW	8.4 kW	8.9 kW	9.3 kW	9.7 kW	10.1 kW	10.5 kW
5.6 kW	6 kW	6.4 kW	6.9 kW	7.3 kW	7.7 kW	8.1 kW	8.5 kW	8.9 kW	9.3 kW	9.6 kW	10 kW

4 FIND YOUR WOODSMAN

Finally, use this kilowatt number to identify the wood burners (on the following page) that best match your needs. Your ideal models will have a high and low kW output on either side of this number.

Woodsman Fire Range



SERENE PETITE

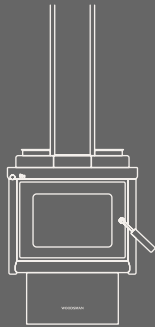

**KANAKU
PEDESTAL**



**KANAKU
WOOD BOX**



SERENE

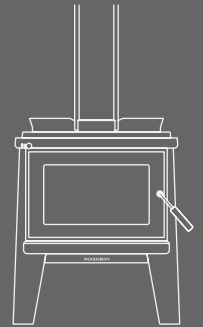

COLERIDGE

	HIGH		LOW		HIGH		LOW		HIGH		LOW		HIGH		LOW	
A	6.2 kW	4.5 kW	9.0 kW	8.0 kW	9.0 kW	8.0 kW	8.5 kW	6.2 kW	8.9 kW	7.5 kW						
B	1.85 kg/h	1.17 kg/h	2.0 kg/h	1.8 kg/h	2.0 kg/h	1.8 kg/h	2.38 kg/h	1.65 kg/h	2.55 kg/h	1.94 kg/h						
C	60.7%	70.6%	69.0%	79.0%	69.0%	79.0%	63.8%	67.9%	62.3%	69.6%						
D	25.7L		26.2L		26L		46.7L		60.5L							
E	834H × 411W × 555D		699H × 502W × 473D		800H × 502W × 474D		928H × 501W × 613D		823H × 648W × 638D							
F	300 mm		350 mm		350 mm		400 mm		450 mm							
G	Up to 4		Up to 3		Up to 3		Up to 6		Up to 7							
H	ULEB	NES	ULEB	NES	ULEB	NES	ULEB	NES	ULEB	NES						
I	✓	✓	✓	✓	✓	✓	✓	✓	✓	✓						
J	0.35g/kg		0.3g/kg		0.3g/kg		0.36g/kg		0.49g/kg							
K	66.2%		74%		74%		66.2%		66.3%							
L	×		×		×		2 kW		×							
L	2Y Parts	15Y Firebox	2Y Parts	15Y Firebox	2Y Parts	15Y Firebox	2Y Parts	15Y Firebox	2Y Parts	15Y Firebox						

A Average Heat Output

B Fuel Consumption Rate

C Room Heating Efficiency

D Firebox Volume

E Fire Dimensions

F Max. Log Length

G Approx No. Logs

H Clean Air Approval

I Average Emissions

J Average Efficiency

K Wetback Approved

L Warranty

For more information, visit woodsman.co.nz

Real craft. Quality you can feel. Built to last.

ROBUST CERAMIC GLASS

Highest quality glass supplied by SCHOTT ROBAX®, leaders in fireplace glass.

LONG LASTING PARTS

Use of only the best materials to ensure maximum life of consumable parts.

NEW ZEALAND MADE MILD STEEL

6-8mm steel plate used for high construction strength and ultimate firebox longevity.

TOUGH FIRE BRICKS

Long lasting, compressed Vermiculite SKAMOLEX™ fire bricks, designed to withstand extreme temperatures.

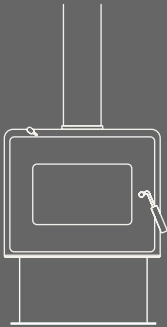

FLARE

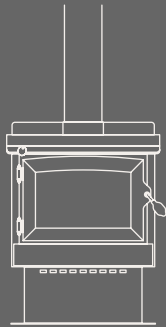

TASMAN MKII

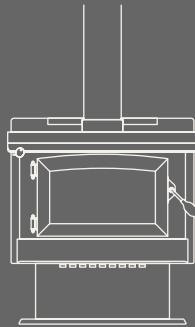

TARRAS MKIII

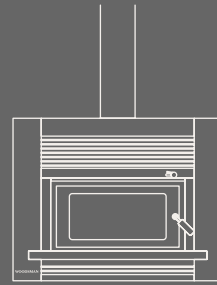

TOTARA

HIGH	LOW
12.0 kW	9.1 kW
3.38 kg/h	2.27 kg/h
64.1%	72.4%

HIGH	LOW
14.3 kW	8.4 kW
4.04 kg/h	2.05 kg/h
64.4%	78.1%

HIGH	LOW
16.9 kW	10.6 kW
4.86 kg/h	2.56 kg/h
63.1%	74.1%

HIGH	LOW
7.3 kW	4.7 kW
2.26 kg/h	1.13 kg/h
57.5%	75.2%

55.5L
780H × 630W × 602D
450 mm
Up to 6

55.6L
808H × 615W × 630D
450 mm
Up to 6

75.3L
824H × 765W × 640D
600 mm
Up to 10

32.5L
650H × 840W × 62D
450 mm
Up to 2

ULEB	NES
×	✓
0.97g/kg	
68%	
2 kW	
1Y Parts	15Y Firebox

ULEB	NES
×	✓
0.5g/kg	
71%	
2 kW	
1Y Parts	15Y Firebox

ULEB	NES
×	✓
0.37g/kg	
69%	
3 kW	
1Y Parts	15Y Firebox

ULEB	NES
×	✓
0.9g/kg	
67%	
×	
1Y Parts	15Y Firebox

ULTRA LOW EMISSION BURNER

ULEBs are the cleanest solid fuel burners. Under the current Air Plan, they can be installed and used indefinitely in Canterbury. ULEBs are tested using the Canterbury Method 1 (CM1), which uses strict real-life operating conditions.

NATIONAL ENVIRONMENTAL STANDARDS

NES are set by the Ministry for the Environment, September 2005. All new wood fires must meet a minimum efficiency level of 65%, plus include emissions of less than 1.5gm of carbon per kg of burnt dry wood. This covers the whole country as the MINIMUM level of compliance – some districts have implemented more stringent levels of compliance.

Serene Petite

Freestanding Ultra Low Emission Burner

26L

FIREBOX
CAPACITY

4 log

FIREBOX
CAPACITY

8mm

STEEL
COOKTOP

Feels streamlined, sleek and petite – a smaller form factor, built to nestle neatly.

Enjoy the traditional comfort of a log fire with the benefit of sustained burn technology, heating your home to a pleasant, even temperature – delivering more fire power from each piece of wood.



Height	834
Width	411
Depth	555

CRAFTED FOR A LONG LIFE

The Serene Petite is fitted with stainless steel air tubes and baffle for long service life and comes with a two year warranty.

ULTRA LOW EMISSIONS – FEEL BETTER ABOUT THE ENVIRONMENT

The Serene Petite outperforms the testing standards for emissions, meaning it can be installed in any New Zealand home.



Ergonomically designed with real human-focused features.

EASY TO LIGHT AND CLEAN

With built-in storage to reduce clutter, the Serene Petite's design is ergonomic and promotes cost-effective ease of use.

GENEROUSLY SIZED FIRE BOX

Fits up to 4 standard sized logs (approx. 120mm x 120mm x 300mm) and the sustained burn technology will keep you warmer for longer on each load of fuel.

SIMPLE TO LOAD FRONT-TO-BACK FIREBOX

The front to back orientation ensures protection from logs rolling out.

HANDY STEEL COOKTOP

The Serene Petite is fitted with a convenient 8mm steel cooktop suitable for use during a power outage.

Dimensions	834H x 411W x 555D
Weight	110 kg
ULEB Approved	Yes
Clean Air Approval	All Zones
Floor Protector	Ash Hearth
Max. Log Length	300 mm
Approx No. Logs	Up to 4

	High	Low
Average Heat Output	6.2 kW	4.5 kW
Fuel Consumption Rate	1.85 kg/h	1.17 kg/h
Room Heating Efficiency	60.7%	70.6%

The Serene Petite requires no electrical installation, no additional components and no complex operating requirements.

WALL INSTALLATION

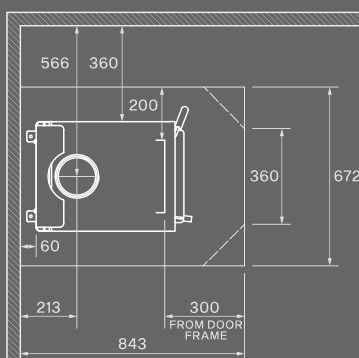

All dimensions and clearances are in mm. Clearances are with factory flue shield.

CORNER INSTALLATION

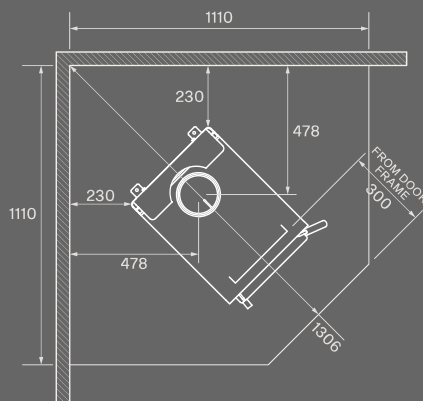

Refer to installation manual for full specifications.

Kanaku

Freestanding Ultra Low Emission Burner

26L

FIREBOX
CAPACITY

3 log

FIREBOX
CAPACITY

8mm

STEEL
COOKTOP

Feels simple and elegant. Ideal for any Kiwi home.

Simplicity is the key and the Kanaku achieves ultra clean burning without the need for fans, or other types of systems which require special operational methods or additional maintenance. Available in two options Pedestal and Wood Box.

WOOD BOX



	Pedestal	Woodbox
Height	699	800
Width	502	502
Depth	473	474

CRAFTED FOR A LONG LIFE

The Kanaku is fitted with stainless steel air tubes and baffle for long service life and has a two year warranty.

ULTRA LOW EMISSIONS – FEEL BETTER ABOUT THE ENVIRONMENT

The Kanaku outperforms the testing standards for emissions, meaning it can be installed in any New Zealand home.



Ergonomically designed with real human-focused features.

USER FRIENDLY & EASY TO MAINTAIN

Kanaku's design is ergonomic and promotes cost-effective ease of use.

EASY SERVICE

The simple baffle removal system ensures easy servicing for chimney sweeps.

Dimensions – Pedestal	699H × 502W × 473D	
– Wood Box	800H × 502W × 474D	
Weight	100 kg	
ULEB Approved	Yes	
Clean Air Approval	All Zones	
Floor Protector	Ash Hearth	
Max. Log Length	350 mm	
Approx No. Logs	Up to 3	
	High	Low
Average Heat Output – Pedestal	9.0 kW	8.0 kW
Fuel Consumption Rate	2.0 kg/h	1.8 kg/h
Room Heating Efficiency	69.0%	79.0%

The Kanaku requires no electrical installation, no additional components and no complex operating requirements.

WALL INSTALLATION

CORNER INSTALLATION

PEDESTAL

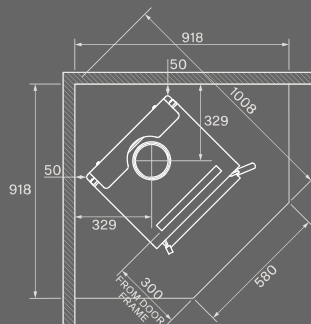
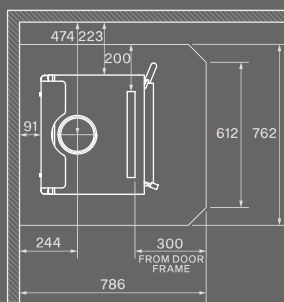

WOOD BOX

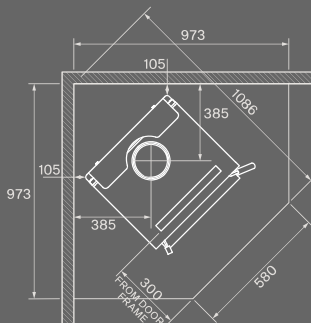
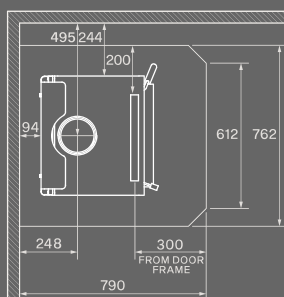

All dimensions and clearances are in mm. Clearances are with factory flue shield.

Refer to installation manual for full specifications.

Serene

Freestanding Ultra Low Emission Burner

47L

FIREBOX
CAPACITY

6 log

FIREBOX
CAPACITY

8mm

STEEL
COOKTOP

Feels streamlined and sleek – a trim form factor, built to nestle neatly.

Enjoy the traditional comfort of a log fire with the benefit of sustained burn technology, heating your home to a pleasant, even temperature. Feel more fire power from each piece of wood.

WOOD BOX



DRAWER

The Serene Drawer includes a no mess ash scoop. This scoop fits neatly into the fire-safe drawer, which has room for kindling and fire-starting tools.



Height	928
--------	-----

Width	501
-------	-----

Depth	613
-------	-----

CRAFTED FOR A LONG LIFE

The Serene is fitted with stainless steel air tubes and baffle for long service life and comes with a two year warranty.

ULTRA LOW EMISSIONS – FEEL BETTER ABOUT THE ENVIRONMENT

The Serene outperforms the testing standards for emissions and wetback use, meaning it can be installed in any New Zealand home.



Designed with you in mind. Real human-focused features.

EASY TO LIGHT AND CLEAN

With built-in storage to improve safety and reduce clutter, the Serene's design is ergonomic and promotes cost-effective ease of use.

UPRIGHT LOAD AND LIGHT HEIGHT

When loading wood or cleaning, the Serene is accessed at standing height without the need for crouching or kneeling.

HANDY STEEL COOKTOP

The Serene is fitted with a convenient 8mm steel cooktop suitable for use during a power outage.

Dimensions	928H × 501W × 613D	
Weight	145 kg	
ULEB Approved	Yes	
Clean Air Approval	All Zones	
Floor Protector	Ash Hearth	
Max. Log Length	400 mm	
Approx No. Logs	Up to 6	
	High	Low
Average Heat Output	8.5 kW	6.2 kW
Fuel Consumption Rate	2.38 kg/h	1.65 kg/h
Room Heating Efficiency	63.8%	67.9%

The Serene requires no electrical installation, no additional components and no complex operating requirements.

WALL INSTALLATION

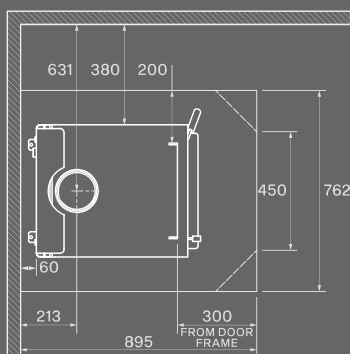

All dimensions and clearances are in mm. Clearances are with factory flue shield.

CORNER INSTALLATION

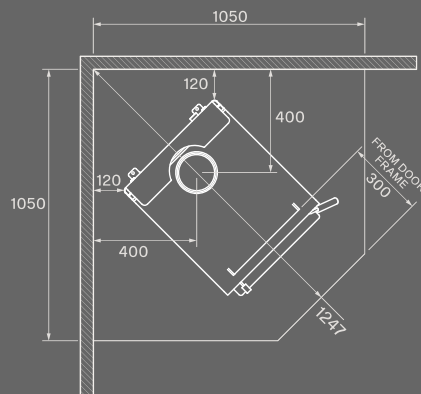

Refer to installation manual for full specifications.

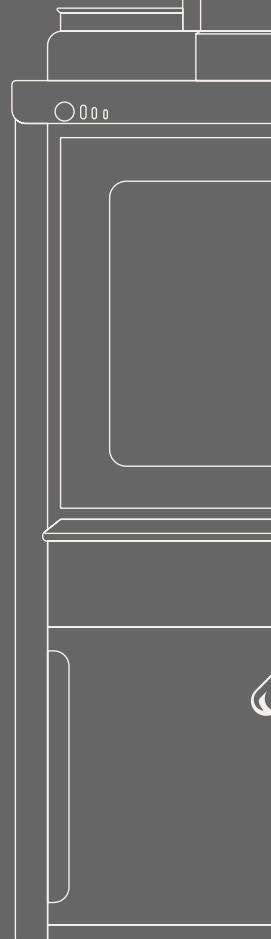

Coleridge

Freestanding Ultra Low Emission Burner

61L

FIREBOX
CAPACITY

7 log

FIREBOX
CAPACITY

6mm

STEEL
COOKTOP

Feels simple and elegant – at home in any large room.

Simplicity is the key and the Coleridge achieves ultra clean burning without the need for fans, or other types of systems that require special operational methods or additional maintenance.

PEDESTAL



LEGS



	Pedestal	Legs
Height	823	823
Width	615	648
Depth	638	638

CRAFTED FOR A LONG LIFE

The Coleridge is fitted with stainless steel air tubes and baffle for long service life and has a two year warranty.

ULTRA LOW EMISSIONS – FEEL BETTER ABOUT THE ENVIRONMENT

The Coleridge outperforms the testing standards for emissions, meaning it can be installed in any New Zealand home.

Designed with you in mind. Real human-focused features.

USER FRIENDLY AND EASY TO MAINTAIN

The Coleridge's design is ergonomic and promotes cost-effective ease of use and can be installed in even the tightest of clean air zones in the country.

EASY SERVICE

The simple baffle removal system ensures easy servicing for chimney sweeps.

HANDY STEEL COOKTOP

The Coleridge is fitted with a convenient 6mm steel cooktop suitable for use during a power outage.

Dimensions – Pedestal	823H × 615W × 638D	
– Legs	823H × 648W × 638D	
Weight	150 kg	
ULEB Approved	Yes	
Clean Air Approval	All Zones	
Floor Protector	Ash Hearth	
Max. Log Length	450 mm	
Approx No. Logs	Up to 7	
	High	Low
Average Heat Output	8.9 kW	7.5 kW
Fuel Consumption Rate	2.55 kg/h	1.94 kg/h
Room Heating Efficiency	62.3%	69.6%

The Coleridge requires no electrical installation, no additional components and no complex operating requirements.

WALL INSTALLATION

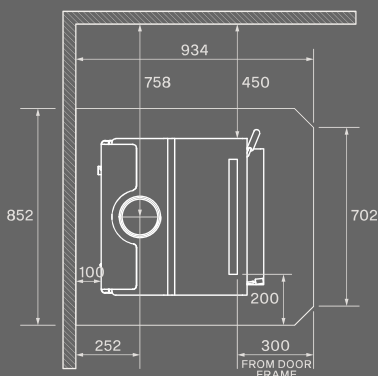

All dimensions and clearances are in mm. Clearances are with factory flue shield.

CORNER INSTALLATION

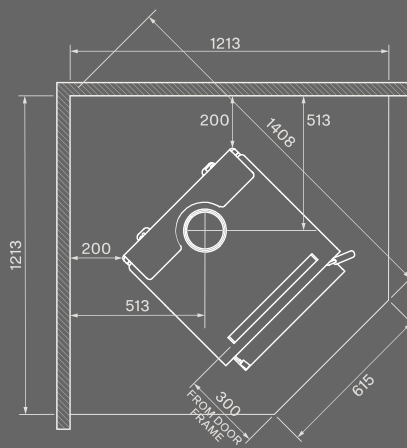

Refer to installation manual for full specifications.

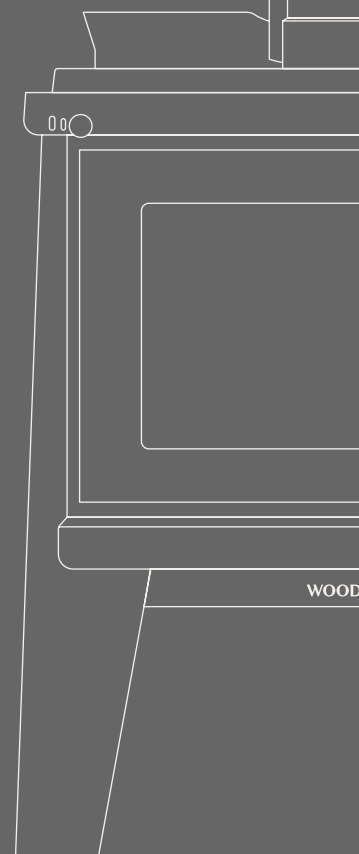

Flare

Freestanding Low Emission Approved Burner

56L

**FIREBOX
CAPACITY**

6 log

**FIREBOX
CAPACITY**

6mm

**STEEL
COOKTOP**

Feels colourful and stylish – like you're making a statement.

The Flare lets you choose the form and colour accent that best suits you with three base options and three accent options available.

WOOD BOX
Red Brown



LEGS
Metallic Brown



PEDESTAL
Charcoal



Height	780
Width	630
Depth	602

COLOUR OPTIONS

Red Brown
Metallic Brown
Charcoal

CRAFTED FOR A LONG LIFE

The Flare is fitted with a stainless steel baffle for long service life and comes with a one year warranty.

CLEAN AIR APPROVED – FEEL BETTER ABOUT THE ENVIRONMENT

The Flare outperforms the National Environmental Standards for emissions and efficiency.

Designed with you in mind. Real human-focused features.

USER FRIENDLY AND EASY TO MAINTAIN

The Flare's design is ergonomic and promotes cost-effective ease of use.

EASY SERVICE

The simple baffle removal system ensures easy servicing for chimney sweeps.

HANDY STEEL COOKTOP

The Flare is fitted with a convenient hidden 6mm steel cooktop suitable for use during a power outage.

Dimensions	780H × 630W × 602D	
Weight	140 kg	
ULEB Approved	No	
Clean Air Approval	Yes (except 0.7 Zones)	
Floor Protector	Ash Hearth	
Max. Log Length	450 mm	
Approx No. Logs	Up to 6	
	High	Low
Average Heat Output	12.0 kW	9.1 kW
Fuel Consumption Rate	3.38 kg/h	2.27 kg/h
Room Heating Efficiency	64.1%	72.4%

The Flare requires no electrical installation, no additional components and no complex operating requirements.

WALL INSTALLATION

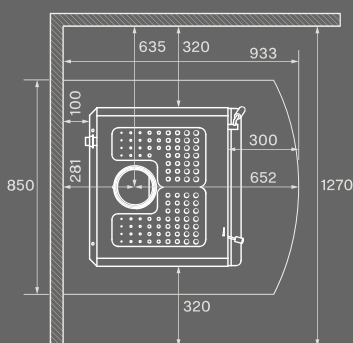

All dimensions and clearances are in mm. Clearances are with factory flue shield.

CORNER INSTALLATION

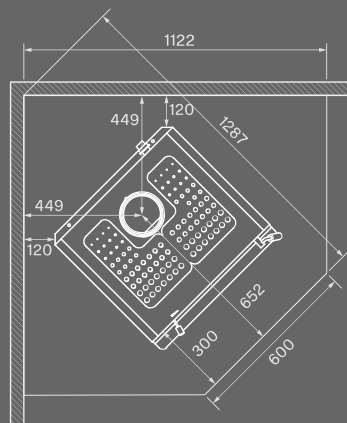

Refer to installation manual for full specifications.

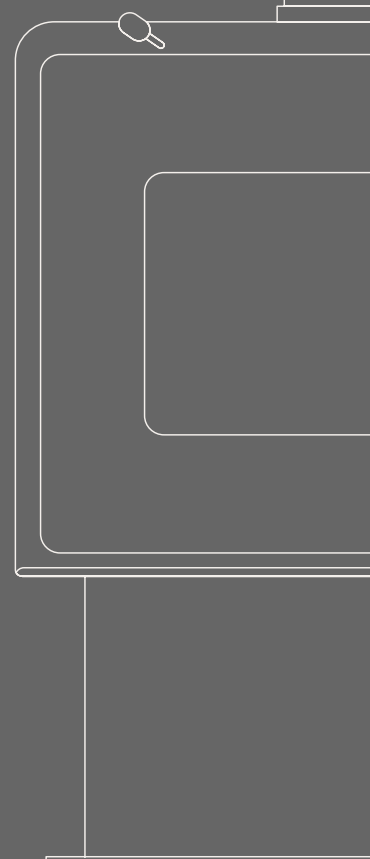

Tasman MkII

Freestanding Low Emission
Approved Burner

56L

FIREBOX
CAPACITY

6 log

FIREBOX
CAPACITY

6mm

STEEL
COOKTOP

**Feels like the right
mix of traditional
and contemporary.**

Designed for medium to large living areas, the Tasman places a classic wood burner design upon a modern, easy-clean pedestal base.



Height 808

Width 615

Depth 630



CRAFTED FOR A LONG LIFE

The Tasman is fitted with a stainless steel baffle for long service life and comes with a one year warranty.

CLEAN AIR APPROVED – FEEL BETTER ABOUT THE ENVIRONMENT

The Tasman MkII outperforms the National Environmental Standards for emissions and efficiency.

Designed with you in mind. Real human-focused features.

USER FRIENDLY AND EASY TO MAINTAIN

The Tasman's design is ergonomic and promotes cost-effective ease of use.

EASY SERVICE

The simple baffle removal system ensures easy servicing for chimney sweeps.

HANDY STEEL COOKTOP

The Tasman is fitted with a convenient 6mm steel cooktop suitable for use during a power outage.

Dimensions	808H × 615W × 630D	
Weight	140 kg	
ULEB Approved	No	
Clean Air Approval	Yes	
Floor Protector	Ash Hearth	
Max. Log Length	450 mm	
Approx No. Logs	Up to 6	
	High	Low
Average Heat Output	14.3 kW	8.4 kW
Fuel Consumption Rate	4.04 kg/h	2.05 kg/h
Room Heating Efficiency	64.4%	78.1%

The Tasman requires no electrical installation, no additional components and no complex operating requirements.

WALL INSTALLATION

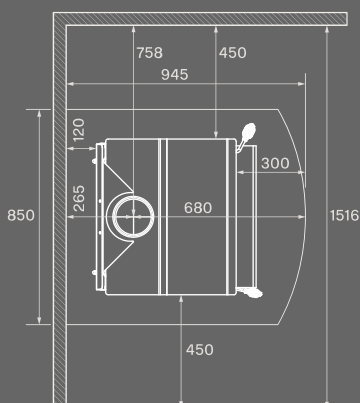

All dimensions and clearances are in mm. Clearances are with factory flue shield.

CORNER INSTALLATION

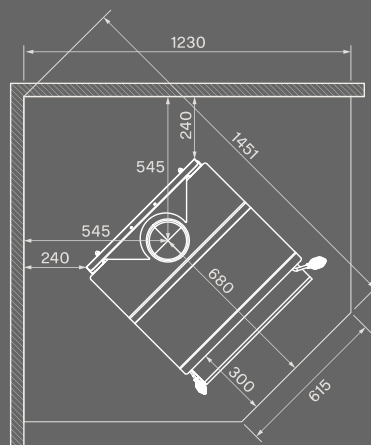

Refer to installation manual for full specifications.

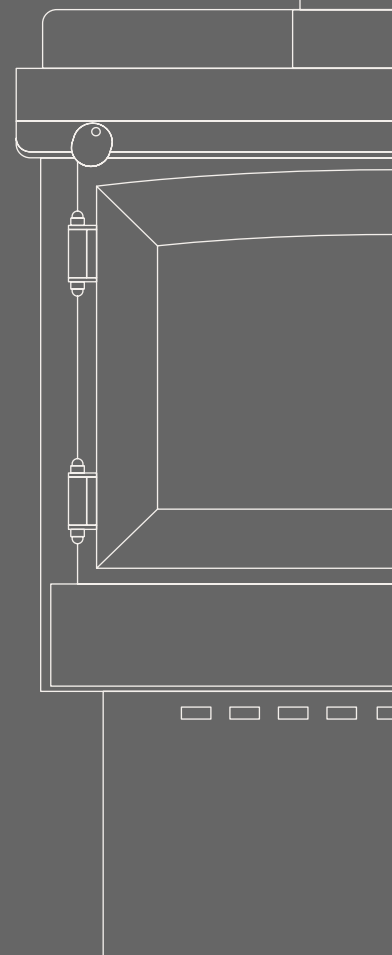

Tarras MkIII

Freestanding Low Emission
Approved Burner

76L

FIREBOX
CAPACITY

10 log

FIREBOX
CAPACITY

8mm

STEEL
COOKTOP

**Feels warm and
cosy – right in a
big room setting.**

Designed to heat large living areas quickly and efficiently, the Tarras MkIII is a cost-effective workhorse (with thoroughbred good looks) that gets the job done and keeps everyone cosy.



Height	824
Width	765
Depth	640

CRAFTED FOR A LONG LIFE

The Tarras is fitted with a stainless steel baffle for long service life and comes with a one year warranty.

CLEAN AIR APPROVED – FEEL BETTER ABOUT THE ENVIRONMENT

The Tarras MkIII outperforms the National Environmental Standards for emissions and efficiency.



Designed with you in mind. Real human-focused features.

USER FRIENDLY AND EASY TO MAINTAIN

The Tarras's design is ergonomic and promotes cost-effective ease of use.

EASY SERVICE

The simple baffle removal system ensures easy servicing for chimney sweeps.

HANDY STEEL COOKTOP

The Tarras is fitted with a convenient 8mm steel cooktop suitable for use during a power outage.

Dimensions	824H × 765W × 640D	
Weight	160 kg	
ULEB Approved	No	
Clean Air Approval	Yes	
Floor Protector	Ash Hearth	
Max. Log Length	600 mm	
Approx No. Logs	Up to 10	
	High	Low
Average Heat Output	16.9 kW	10.6 kW
Fuel Consumption Rate	4.86 kg/h	2.56 kg/h
Room Heating Efficiency	63.1%	74.1%

The Tarras requires no electrical installation, no additional components and no complex operating requirements.

WALL INSTALLATION

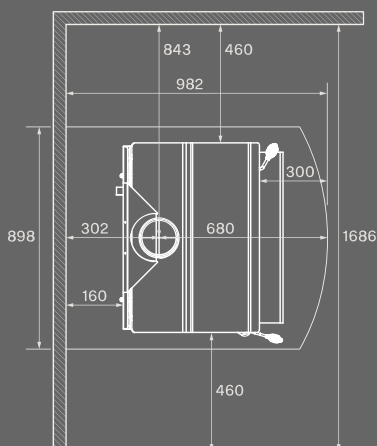

All dimensions and clearances are in mm. Clearances are with factory flue shield.

CORNER INSTALLATION

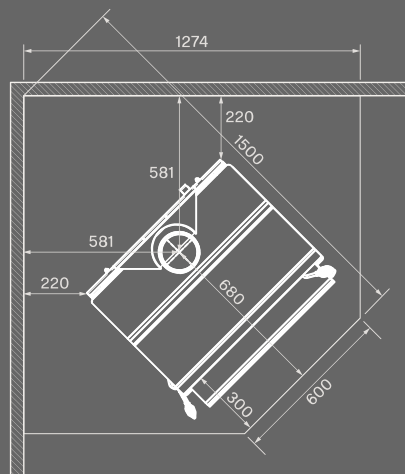

Refer to installation manual for full specifications.

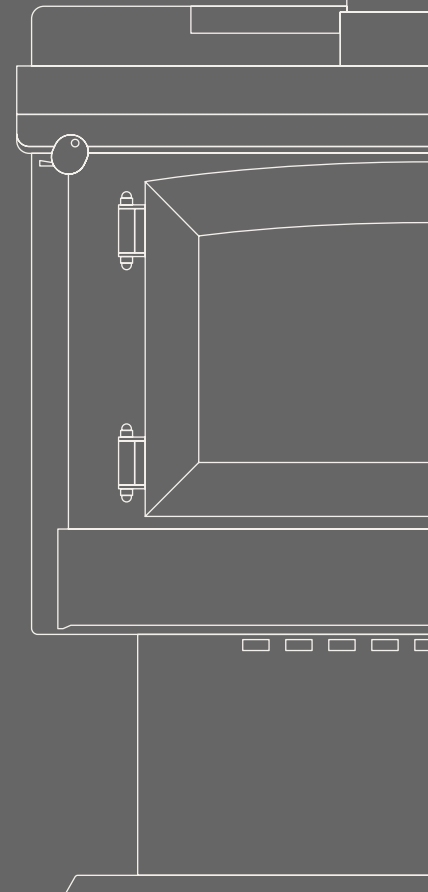

Totara

Fireplace Insert Low Emission Approved Burner

33L	2 log	6mm
FIREBOX CAPACITY	FIREBOX CAPACITY	STEEL FIREBOX

Feels like the ideal upgrade from your brick fireplace.

It's the perfect option for upgrading your brick open fireplace or a stylish choice for keeping your modern home snug and warm.

CRAFTED FOR A LONG LIFE

The Totara is fitted with a stainless steel baffle for long service life and comes with a one year warranty.

CLEAN AIR APPROVED – FEEL BETTER ABOUT THE ENVIRONMENT

The Totara outperforms the National Environmental Standards for emissions and efficiency.



FASCIA

Height	650
Width	840
Depth	62

Designed with you in mind. Real human-focused features.

USER FRIENDLY AND EASY TO MAINTAIN

The Totara's design is ergonomic and promotes cost-effective ease of use.

EASY SERVICE

The simple baffle removal system ensures easy servicing for chimney sweeps.

INSTALLATION OPTION

Zero clearance box available (for timber framing).

Dimensions	650H × 840W × 62D	
Weight	90 kg	
ULEB Approved	No	
Clean Air Approval	Yes (except 0.7 Zones)	
Floor Protector	8mm Ceramic Tiles	
Max. Log Length	450 mm	
Approx No. Logs	Up to 2	
	High	Low
Average Heat Output	7.3 kW	4.7 kW
Fuel Consumption Rate	2.26 kg/h	1.13 kg/h
Room Heating Efficiency	57.5%	75.2%

The Totara requires no electrical installation, no additional components and no complex operating requirements.

INSTALLATION

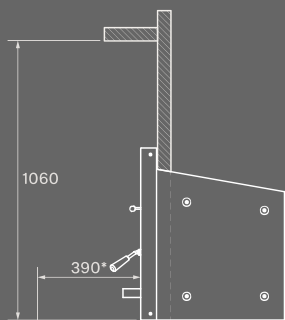
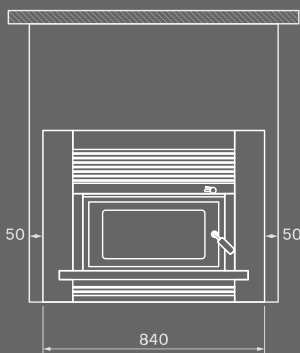

*SEE GRAPH IN INSTALLATION INSTRUCTIONS

All dimensions and clearances are in mm. Clearances are with factory flue shield.

Refer to installation manual for full specifications.

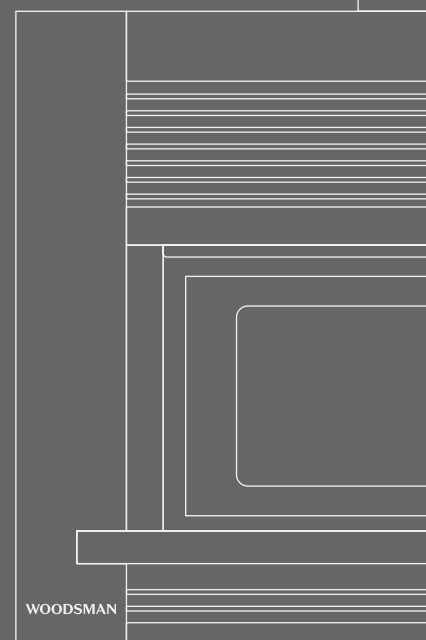

Complement your Woodsman collection

Accessories that fit right in and complete your experience.



Woodsman Wood Stacker

This Woodsman accessory really stacks up.

This great looking unit sorts your big logs, kindling, and fire starting materials — putting everything in its right place, ready to use.

Kiwi made, made to last.

FEATURES

Construction	Solid 1.6mm steel
Finish	Metallic black painted
Assembly	Fully assembled

DIMENSIONS

Height	750
Width	750
Depth	340

Floor Protectors

A range of attractive steel floor protectors offering you an easy and safe solution for keeping the immediate standing room around your Woodsman pristine.

FEATURES

Easy-clean powder-coated finish
Wall or corner options
Available in matt black finish
Stub-proof design
Low profile 4mm finished thickness

WALL

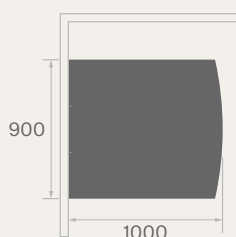

CORNER LARGE

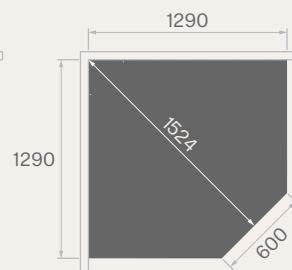

CORNER SMALL

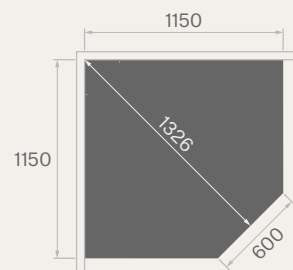

Suitable for all freestanding Woodsman fires.

All dimensions are in mm.

Real after sales service.

Feel good warranties.

15yr

WOODB
WARRANTY

1-2yr

PARTS
WARRANTY

We built your Woodsman to last, and we stand by our workmanship, ensuring you get the best out of your investment — now and in years to come. We have a comprehensive range of replacement parts backed by prompt after-sales service.

The goal is that your Woodsman continues operating as it should and looks great doing it. Ours is a family business with a strong history, and we want whoever is using a Woodsman to be happy for as long as the home fires keep burning.

Handcrafted in
New Zealand since

1887

You can browse and buy our accessories at shop.woodsman.co.nz



Feel warm inside.

Heating your home to a pleasant, even temperature, and supporting a real Kiwi made product.

